



Liquefied Petroleum Gas (LPG)

Loading and unloading systems for pressurised gas - railcars and tank trucks

Propan - Butan - Propylen - Isobutan - Buten



LOADING YOUR FUEL

Dipl.-Ing. SCHERZER GmbH

Company profile:

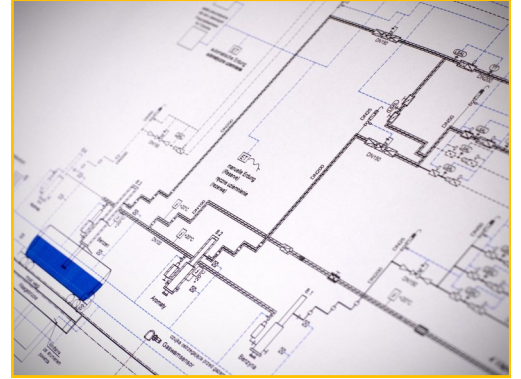

Welcome to der Dipl. Ing. SCHERZER GmbH

For more than 50 years Dipl.-Ing. SCHERZER GmbH is now involved in planning and turnkey construction of plants for handling and storage of liquid and gaseous products. Based on this experience, we are one of the leading companies in our business area.

Our customers from the petroleum and chemical industries and from a range of other sectors at home and abroad value our groundbreaking technology and our high quality standards as well as our ability to address custom applications while optimizing the economic and environmental aspects of our designs.

Quality - Safety - Service

Social and environmental policy requirements place high demands on our company on a daily basis, as do constantly changing safety guidelines. These standards are our top priority. Consequently, all areas of the company are subject to a quality management system and certified in accordance with DIN EN ISO 9001:2015.

As a specialized company, we do, of course, have all legal permits necessary to operate both in Germany and abroad.

Our subsidiary, Scherzer Umwelttechnik GmbH, will handle our after-sales service, allowing us to be there for you long after a successful start-up. Maintenance, the procurement of spare parts, and other important services will guarantee the continuous operation of your plant.

Range of services

Our comprehensive range of services includes:

- Concept design including essential performance characteristics
- Inventory surveys
- Basic engineering
- Detail engineering
- Delivery of equipment
- Assembly of unit (for turnkey contracts)
- Supervision (for assembly by customer)
- Training at manufacturers place and/or at site
- Commissioning
- Performance check
- Documentation and handover
- Services

Scope of supplies and services

Our portfolio covers a wide range, allowing us to meet almost every requirement. In addition to new construction, it also comprises the retrofit, conversion or expansion of existing plants for the loading and unloading of:

- Railcars
- Tank trucks
- Ships

for transshipment of:

- Light products
(Petrol/Gasoline, Diesel, Jet fuel, etc.)
- Dark products
(Crude oil, Bitumen, etc.)
- Chemical products
(Arenes, Acids, etc.)
- Stable gas condensate
- Liquid gases
(Propane, Butane, LPG, etc.)
- Biodiesel / Bioethanol

The **scope of our services** covers also the new construction and reconstruction of tank farms as well as peripheral components and systems such as:

- Vapor recovery units (VRU)
- Vapor pendulum systems
- Fire-fighting systems
- Product and pump systems
- Drainage systems
- Power-supply systems
- Automation technology
- Control and monitoring systems
- Product data logging
- Railroad lines

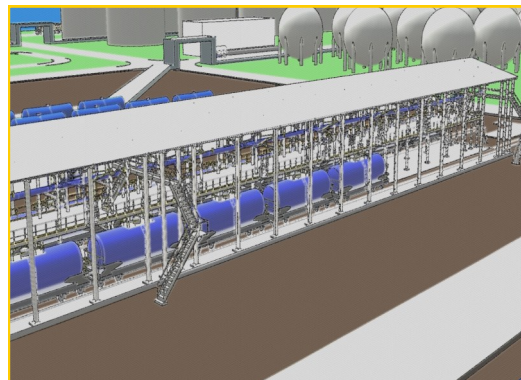

Loading- and unloading facilities for filling and discharge of pressurised gas - railcars and tank trucks with liquid hydrocarbon gases in automatic mode

Dipl.-Ing. SCHERZER GmbH is specialized in loading- and unloading facilities with the highest demands to plant technology.

The transshipment terminals are individually designed according the requirements of the customer and according to the national standards and guidelines. For this purpose, the plant technology is individually designed for the German / Central European market as well as for the Russian market according to the country-specific conditions.

The facilities are configured as specified by the customer or based on our long years' experience and include the following processes:

- Design of loading- and unloading capacities (Filling positions)
- Process engineering calculations (thermodynamic calculations)
- Operator friendly and easy to maintain **Loading-Skids in modular design**
- Degree of automation (electrical/instrumentation)
- Proprietary programmable logic controller (SPS):
(Visualization system, loading databases, tankfarm management)
- Measuring instruments and data acquisition system (Mass- / Volume flow)
- Safety related equipment:
(Video control system, leakage- and fire detection systems, sprinkler systems)
- Supervision and commissioning
- Training of the operators
- Start up until ready for operation handover of the facility

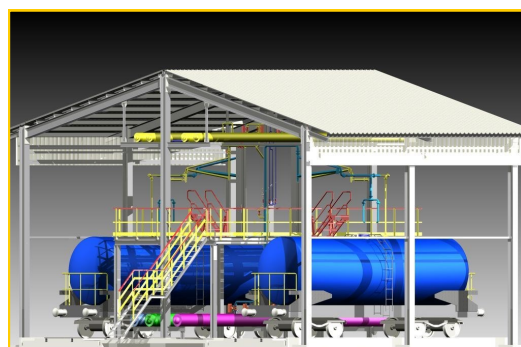

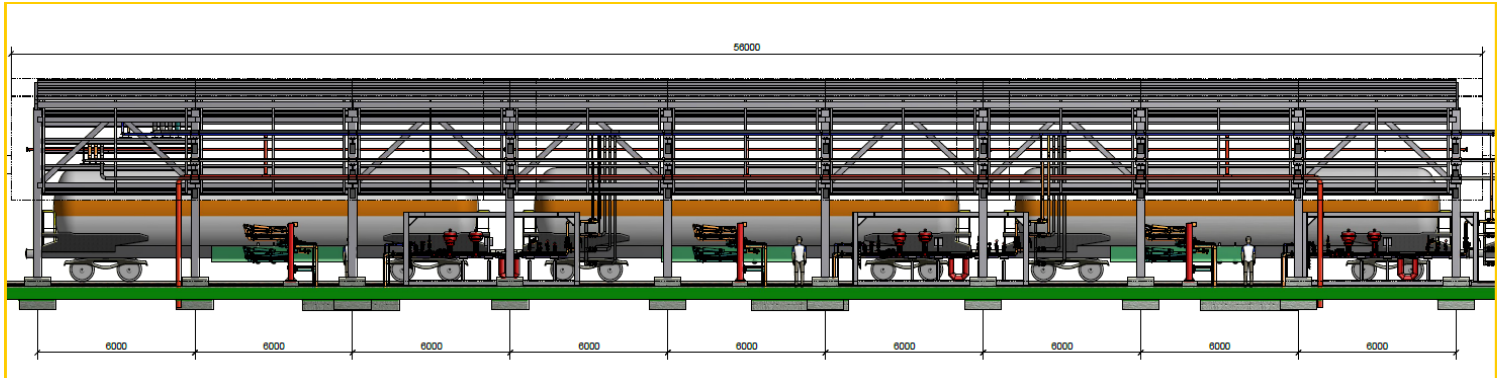

The **concept** of facilities handling liquid hydrocarbons and mixtures thereof meets the highest requirements in terms of fire protection and operational safety and user-friendliness of the complete automated plant.

- **Design pressure:** 4.0 MPa PN40
- **Design temperature:** -60 °C to +40 °C
- **High operational safety:**
Operability guarantee with specified design data
- **Plant performance:**
Guarantee of required daily and annual capacities
- **Quality assurance:**
When handling more than one liquid hydrocarbon via product distributor.

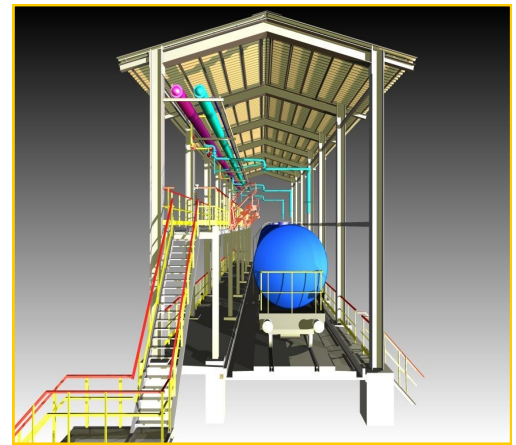

Planning and documentation

Dipl.-Ing. SCHERZER GmbH plans and equips loading and unloading plants for liquid hydrocarbon gases in and out of special tank wagons with state-of-the-art technology and in conformity with official national provisions.

The project documentation is drawn up in the following planning steps:

Basic Engineering or Basic projects

- Site plan and facility layouts
- Procedural design
- Determination/calculation of investment cost
- Basis for tenders
- Assistance with approval planning / Authority-Engineering

Detail Engineering or working project

- Installation drawing in 3D-model
- Piping- & Instrumentation - diagrams and isometrics
- Electrical engineering / measurement & control systems and instrumentation
- Preparation / validation of the statical calculation and steel construction static
- Final design of the equipment, specifications, data sheets
- Video control and gas warning system
- Damage detection, Alarm- and fire fighting system
- Safety- and risk planning

Mounting supervision and commissioning / After-Sales-Service

Final documentation (As-Built-Version)

Installation-, operating- and maintenance manuals

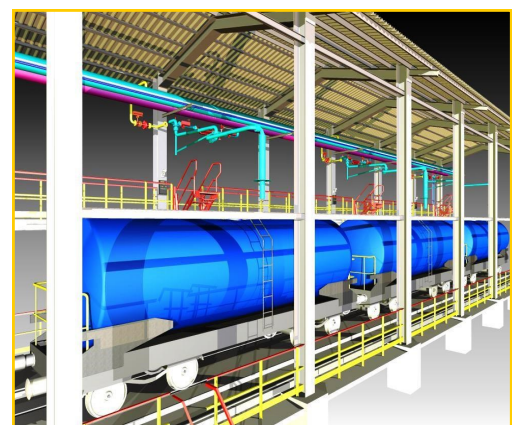
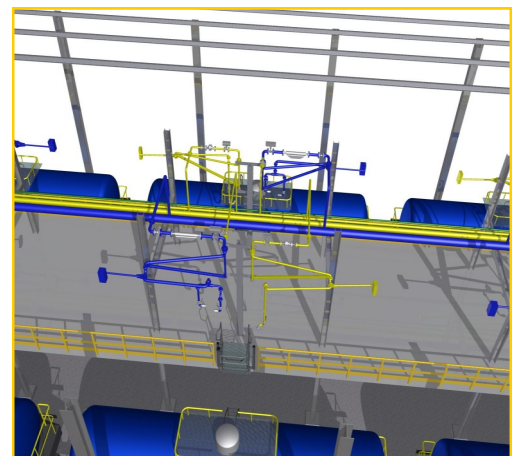



Planning- and execution phases

Design, execution and construction differ im roughly in:

- Documented examination of the existing plant (stock survey)
- Evaluation of realization of the project (feasibility study)
- New construction of transshipment facilities
- Modernization and reconstruction of existing plants
- After-Sales-Service

Preconditions:

The design of the systems is always based on the customer's requirements and the local conditions:

- Climatic and geologic local conditions
- Performance data with daily and annual output
- Plant operation with planned operating times
- Number of the products to be loaded and the transfer quantities
- Technical requirements and components of the system to be built
- Environmental protection standards
- Other special requirements

Engineering design:

Based on customer's technical requirements and standards, Dipl.-Ing. SCHERZER GmbH will prepare the plant layout and the process engineering design for the specific operation, incorporating innovative engineering solutions and the best available technology (STATE OF THE ART):

- Loading- or unloading systems pressurised gas - railcars and tank trucks
- Bottom (un-)loading or Top (un-)loading, (depending to the connector at the compressed gas tank)
- single- or double-track tank wagon (un-)loading bays
- Installation options of the pressurised gas - railcars and tank trucks
- Swivel joint loading systems for liquid phase and gas phase
- Manual or partly automatic (un-)loading
- Safety precaution (Barrier, optical signalling system)
- Power supply units, pump stations, sprinkler systems
- Earthing, gas warn systems, video control systems

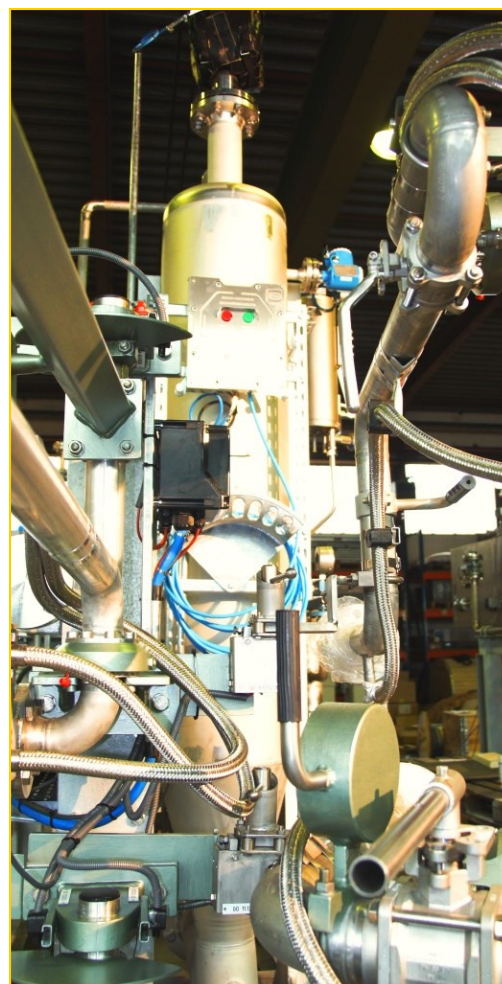
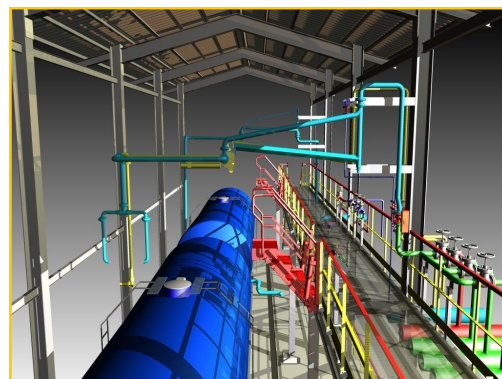



Modular construction of the (un-) loading station

Engineering and construction inside planned boundaries

The engineering and construction of the (un-)loading stations is carried out by a parametric 3D CAD software (Autodesk Inventor) for creating spatial models (3D). The models can be influenced in a targeted and controlled manner by changing the input values. Mechanical motion sequences can be represented as a video sequence.

The necessary drawings (2D) of overviews, assemblies and individual parts are made in a separate working step based on AutoCAD. All changes to the models (3D) are automatically tracked in the drawings (2D).

The loading stations, including the loading skids, are essentially designed as modular steel constructions. However, customer-specific pipe classes and E / MSR specifications are respected. As evidence of the load-bearing safety, the usability and the durability of the loading stations, the static calculation (static) of the steel and piping construction is carried out.

Manufacturing, premounting and inspection in our own production site

- Steel construction in hot-galvanized design including all supports for piping and equipment
- Piping material according specified pipe class
- Complete functional piping, sleeving and wiring of the loading skid as a functional unit
- Integrity check, pressure test, leak test, NDE (non destructive examination tests of welds, corrosion protection, insulation and acceptance according to the pressure equipment directive
- Gratings for safe access of individual free areas in the area of the loading area (maintenance area)
- Roof cover and side cover
- Anchoring and fixing material

Delivery, mounting and commissioning

- Packing and delivery of the loading stations including crane for loading the skid on low loaders
- Building site facilities and clearing of all necessary work including the delivery and removal of necessary equipment and supplies
- Scaffolding for mounting of steel construction and final assembly
- Mounting of the loading skids and all components which must be dismantled or not mounted for the safe transport of the loading skid
- Commissioning and fine adjustment of the respective equipment
- Mechanical functional testing and signal loops and interlocking checks
- Final inspection with commissioning test: Test loading including training of the operator

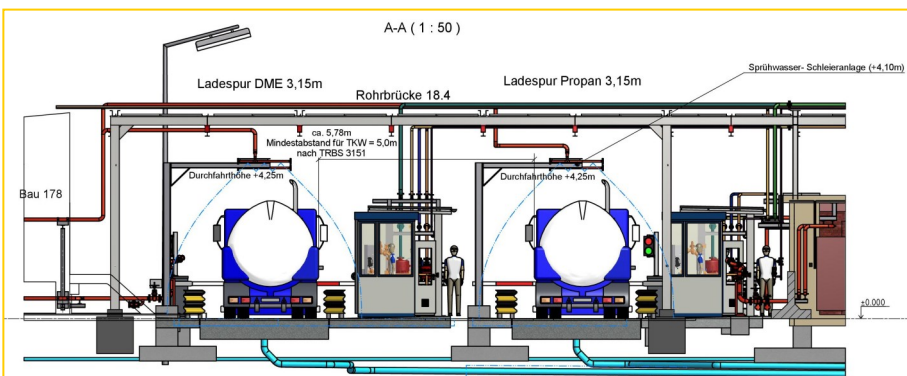
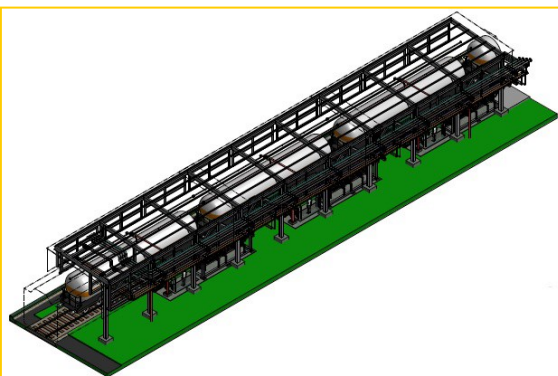

Essential plant components

Loading and unloading stations mainly consist of:

- **Steel construction** (Skid) to accommodate all pipes, valves, instruments and loading arm stands
- **Loading arm stands** (Hot-galvanized and / or painted carbon steel) for the socket of the loading arms including resting keys and initiators for monitoring the parking position
- **Swivel joint loading arms** in cantilever construction (stainless steel) with spring force cylinder as weight compensation
- **Pump system** (for unloading units) with thermosiphon system (liquid lubricated double mechanical seal) and feed tank
- **Liquid gas evaporator** (water vapor or electric) to support the discharge pump system
- **Mass flow** rate measurement with batch controller for the detection of flow and control of output signals
- Static or dynamic **track and / or road truck weighing platform**
- Pneumatically controlled **Double Block & Bleed DBB valves** and ball valves
- Electro-pneumatic **control valves** for flow control
- Instrumentation: **Pressure transmitter, thermal relieve valves TRV**
- **On-site controls** with key switch and emergency stop function
- **Pneumatic rail hooks** for holding the opening of floor valves, especially on compressed gas railcars
- **Earthing testers** for monitoring the forced earthing of railcars and tank trucks during loading
- **Fire detection system** with fire detectors installed in exposed positions
- **Gas warning system** with gas warning sensors installed in exposed positions
- **Sprinkling system** for reducing LPG gas concentrations caused by leaks
- **Video surveillance system** with cameras installed at exposed positions
- **4-stage folding stairs** with monitored rest position for top loading (horizontally movable with protective guard as a fall protection device)

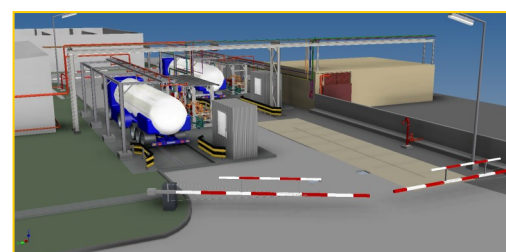
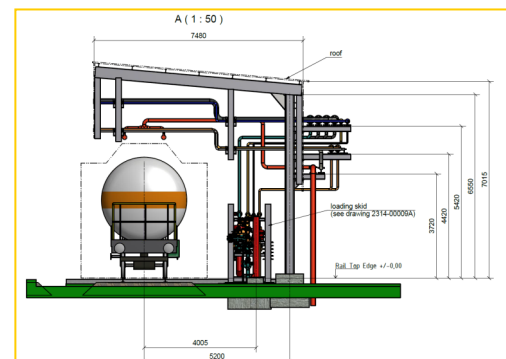
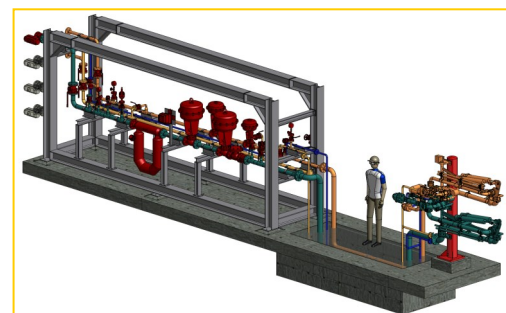

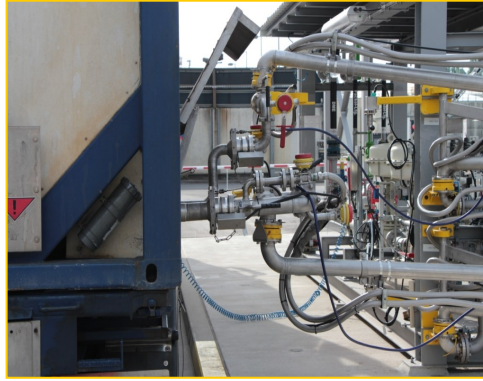
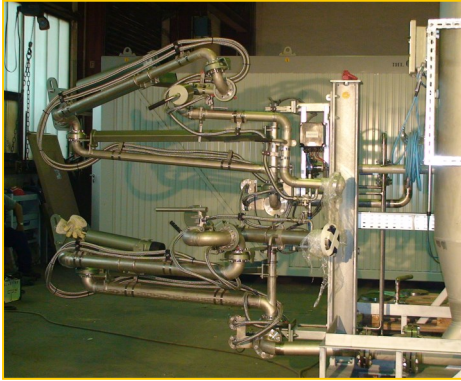

Essential components of the Swivel joint loading arms

- Stand column in hot-galvanized version for safe and functional reception of the loading arms including locking devices for locking in the rest position and Ex-initiator for signaling of the parking position
- Product arm, gas pendulum arm, swivel joints, product touched parts and boom construction in stainless steel
- Loading arm connections on vehicle side: Flange version (railcar), ACME, MERWEDE etc. (tank truck)
- Swivel joints: Double-side flanged design, full flow, with leakage control bore and certificate of „Technical instruction on air quality control“ (TA-Luft)
- Boom construction including counter bearing in stable, torsionally rigid design, for attachment to a stand
- Counterweight or spring force system to facilitate docking and decoupling
- 3-piece welded ball valve, manually operated, full flow, with certificate of „Technical instruction on air quality control“ (TA-Luft)
- Safety separating clutch STK, which prevents the loading arm from breaking off and uncontrolled leakage of the product by means of two self-closing clutch halves, in case the vehicle leaves the connection area while the loading arm is connected. The operation is carried out without any external energy, before the loading arm reaches a dangerous stretching position.
- Ex initiator for signaling "Safety Disconnecter" decoupled
- Unloading and purge unit for the space between the safety separating clutch and the ball valve of the loading arm
- Handle for easy handling of the loading arm

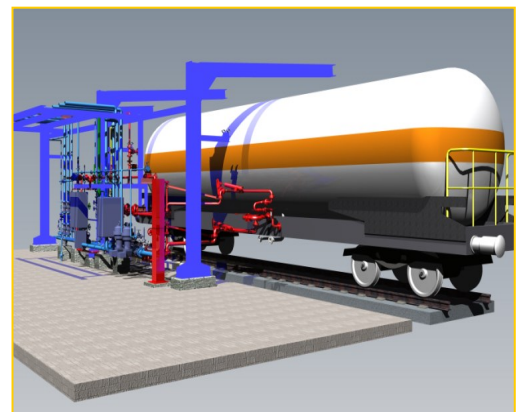
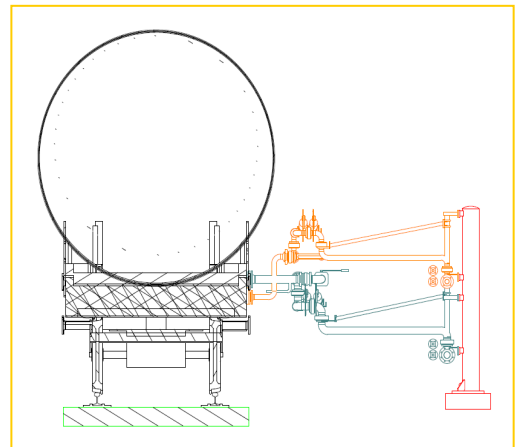

The loading arms are assigned according the project - specific design adapted to all tank trucks and railcars.

Workspace planning in 3D is unavoidable to recognize and avoid collisions.

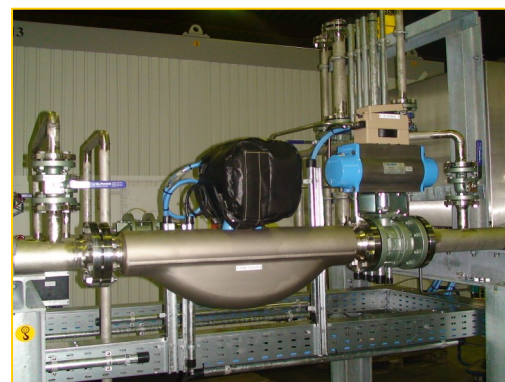
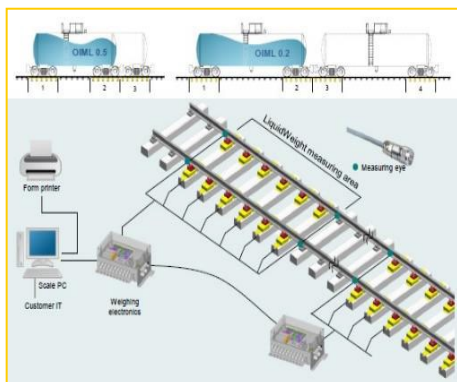

Description of the Data acquisition system

A data acquisition system is used for:

- Presetting of the handling volume per loading operation
- Compliance with the required flow rates
- Automatically controlled and pressure shock free loading stop when the quantity setting is reached

Metering principle for data acquisition

- Calibrated track and / or road truck weighing platforms for weighing during and immediately after loading (Optimal with double load cells)

Further flow measurement principles

for an independent quantity measurement in the conveying path of the (un-) loading stations

- Ultrasonic - flow measurement
- Vortex meter - flow measurement
- Coriolis - flow measurement

Calibration regulated alternative

The flow metering principles mentioned can be used to determine and record the filled product quantities per compressed gas container as a **calibration approved meter** in connection with the corresponding evaluation electronics (batch controller). In this case, the vehicle weighing platform can be used as a checkweigher.

Loading computer system

The loading data can be registered, managed and the loading document can be printed in the company's own loading computer. The loading data can be exported to the host system of the operator.



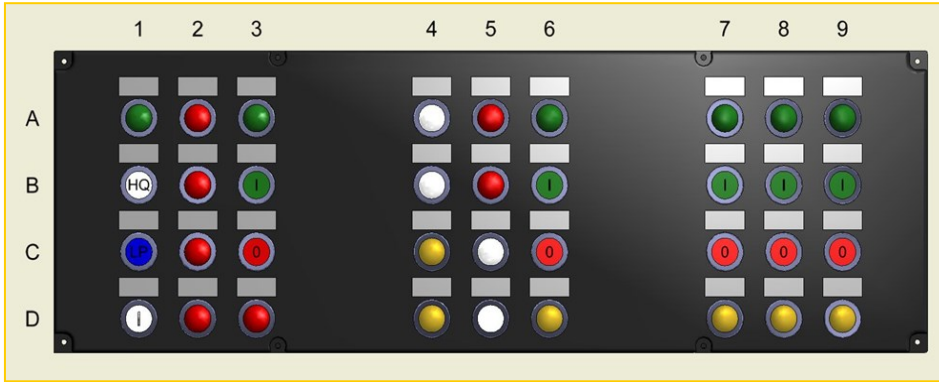

Description of the company own Automation system

Control, regulation and securing of the loading plant

The process control system and the programmable logic controller (PLC) for process control, regulation and backup of the system can be installed in the separate electrical container or integrated into a customer-specific control room of the LPG tankfarm. The process control system monitors all safety-relevant interlocks of the entire LPG (un-) loading station, transfers loading data to the individual on-site control points and controls the loading via the data acquisition system (loading control, opening / closing of the pneumatic valves).



Process visualization system

The PC-based WinCC (Windows Control Center) is used as a process visualization system as a human-machine interface (HMI). The visualization system is used for the operation of valves, visualization of alarms and messages and for the acquisition of measured values, as well as for the provision of data interfaces to the data acquisition system and to the loading computer system.

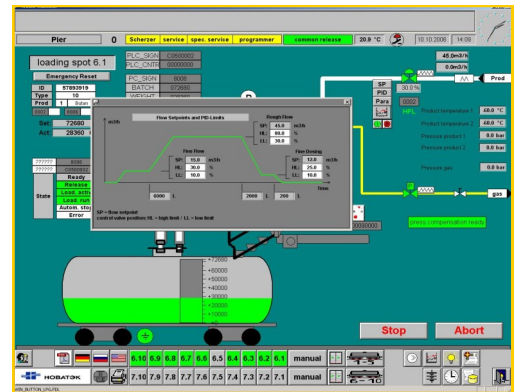

The PC system can be installed in the separate electrical control container or integrated into a customer-specific control room of the LPG tankfarm.

Uninterruptible power supply

The entire automation system is supplied with power for 60 minutes by means of an uninterruptible power supply (UPS) for faults in the power supply system.





Additional components of a (un-) loading facility

Low-voltage switchboard

The low-voltage switchgear supplies the field devices, such as valves, instruments, electric heat trace, lighting, a.o., with the voltage levels 380/220 V AC and 24 V DC via fuse outputs.

Gas warn device

Gas warn system with gas warning sensors installed in exposed positions.

The gas warning system signals:

20 %	UEG	➔	Alarm (Horn and flashlight)
40/50 %	UEG	➔	Switch off the system

The signals are processed and monitored in the PLC.

Emergency stop function

When an emergency stop button is pressed, the entire loading operation is interrupted.

The spring-mounted valves are automatically switched to the safety position when disconnected from the mains.

An "emergency stop" button is integrated in the operating room for the individual loading stations, which, when actuated, interrupts the respective loading.

Optional:

Electric - control container (optional)

The electric control container is a combined container equipped with:

- Low voltage switchgear
- UPS system for the power supply of the loading station in case of faults in the external power supply
- Process control system, programmable logic controller (PLC), process visualization, data requisition system, loading computer
- Intercom system, telecommunication
- Heating and air conditioning system

The electrical room can be equipped additionally with an automatic CO₂-fire fighting unit.

Weatherproof cabin (optional)

Weatherproof cabins can be located near to the (un-) loading stations. They are used to assist the operator during monitoring of the loading process in cold seasons. The cabins are insulated and can be equipped with heating, intercom and telecommunication.



Technology for Unloading systems

of pressurised gas - railcars and tank trucks

Unloading pump system

The discharge pump system is used to transport the product from the pressure tank into the storage tank.

Generally self-regulating vertical centrifugal pumps with low NPSH values are used for the unloading processes. FSV supply systems are installed as a vertical stainless steel pipe in front of the pump (-1/+25 bar) according to the „Pressure Equipment Directive“.

The PLS control of the LPG unloading points starts the product pump in automatic mode for unloading the next pressure tank. The control and monitoring of the evacuating product pump is carried out in the visualization system (DCS) of the central control room. With an emergency stop at the LPG unloading point, the exhausting product pump is also switched off.



Technical data (Example):

Main parameters:

- Fuel: Liquefied petroleum gas
- Solids: none
- State of aggregation: Liquid
- Flow rate (Design): 100 m³/h max. 120 m³/h
- Delivery head (Design): 100 m C.L.
- NPSH (Plant): 0 m
- Fluid group (DGRL): Dangerous fluid (fluid group 1)

Pump:

- min. required flow rate: 0,0 m³/h
- Geodetic height: min. 20,0 m at Q = 0 m³/h (operation)
- Required feed height: 2,5 – 3,0 m
- NPSH required: < 0,1 m
- Power requirement: 40 kW (recommended motor: 55 kW)
- Materials: cast material 1.4408; rolling material 1.4571

Accessories:

- Coupling / motor with protective roof
- Thermosiphon system (liquid lubricated double mechanical seal)
- FSV system (feed tank)





Liquid gas evaporator

The **Liquid gas evaporator** supports the discharge pump system. Hereby the received overpressure in the pressurized gas tanks, which are supposed to be emptied, is assured.

The **Liquid gas evaporator** generates an approx. 2 bar absolute delivery pressure (temperature max. 50 °C) in the gas pressure tank. The nominal output is approx. 1,000 kg / h (for C4-butane).

The evaporation energy can be generated by:

- Steam
- Hot water
- Electrical

Evaporator registers and steam registers are service-friendly retractable at the front of the evaporator. The steam temperature regulator operating independently of the auxiliary energy ensures that the heat transfer medium has a constant operating temperature.

The evaporator is put into operation electrically via the control cabinet. It is ready for operation when the necessary evaporation temperature is present in the unit. Liquefied gas enters the evaporator and is converted into the gas phase up to the specified nominal power.

The solenoid valve closes when there is an overload or a power failure. Design and construction of the evaporator guarantee a low-maintenance and fully automatic evaporator operation.

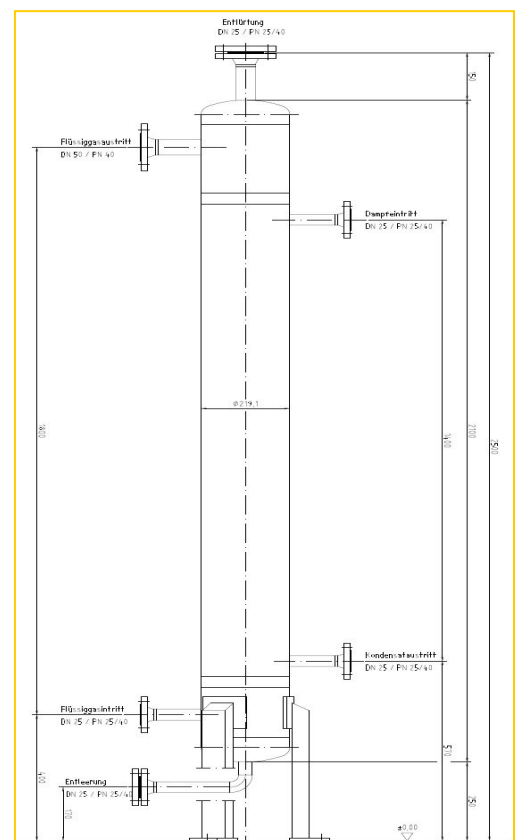

Technical data (Example):

Selection water steam evaporator:

- Heating medium: ND-steam with 0,6 MPa and 150 - 260 °C
- Design: standing, steam heated
- Height: approx. 2,1 m
- Diameter: approx. 273 mm
- Flow rate: 149 kg/h (steam)
- Condensate temperature: max. 90 °C
- Inlet / Outlet: DN 50 / 25 (DIN 2635)
- Material: P265GH

Selection electrical evaporator:

- Indirectly electrical heated LPG evaporator according DIN 30696
- Design according: „Pressure Equipment Directive“ 2014/68/EG
Building regulation: AD 2000 HP 801 no.25, AD - regulations
- Electrical power: approx. 180 KW
- with thermal flooding protection in the liquid gas inlet
- Gas leakage monitoring of the rinsing heat transfer medium



Examples of Railcar - unloading estacades for storage of liquid hydrocarbon gases and their mixtures out of special railcars into storage tanks

The facility for **emptying** of railcars are technologically designed and configured according to customer requirements such as railcar fillings.

Design data of the unloading system: (Example)

- Two track unit up to 2 x 32 RTC (Rail tank car)
- Discharge rate / day 128 RTC
- Workers at the estacade 4
- Daily capacity max. up to 6,780 m³/d
3,870 T/d
- Reserve time / day* 1 hour/d
- Yearly capacity (340 days/year) 1,315,800 T

* The reserve time changes at low temperatures, due to the fact that the railcar relaxation up to 0,7 bar takes less time.

Description of the technological operating systems:

In detail, the operating systems are designed for the complete railcar loading / unloading estacades so that compressors are provided for the unloading in the gas pendulum system or vaporizers for unloading systems without gas pendulum systems in order to ensure the necessary pressure build-up in the railcar for the unloading process.

Apart from that, the operating systems to be provided as for a railcar loading system.

Unloading systems:

- Swivel joint loading arms 2 x DN40 for product side are used for discharge of the liquid hydrocarbon gases and their mixtures.
- Swivel joint loading arm 1 x DN40 for vapor side is used for admission flow of the railcar with an over pressure $\Delta p \geq 1$ bar.

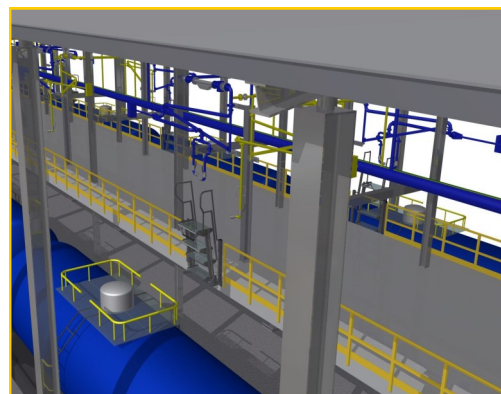
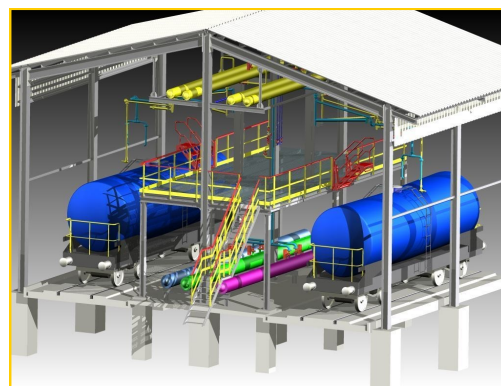

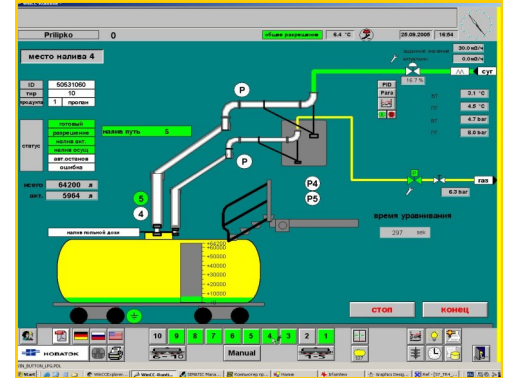
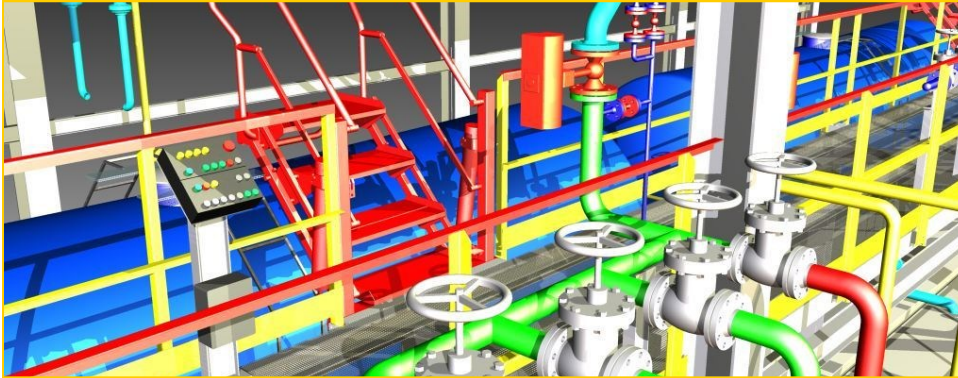

Examples of Railcar - loading estacades

for loading of liquid hydrocarbon gases and their mixtures into special railcars

The systems are technologically designed and configured for the filling of railcars according to the customer's requirements.

Design data of the loading system: (Example)

- Two track unit up to: 2 x 32 RTC (Rail tank car)
- Filling capacity: 128 RTC/d
- Workers estacade 4
- Daily capacity max.: 6,780 m³/d
3,870 T/d
- Reserve time / day: 6 hours/d
- Yearly capacity (340 days): 1,315,800 T

Description of the technological operating systems

In detail, the following operating systems are designed for complete railcar loading stations. The two track loading estacade is designed for max. 32 RTC / track. The railcars are accessible by horizontally movable folding stairs for coupling and decoupling of the swivel joint loading arms, sampling and sealing of the railcars.

Filling systems

The filling systems per loading position mainly consist of:

- Swivel joint loading arm with quick-acting-coupling for product side and gas side
 - Relief system to the flare
 - Nitrogen purge of the loading unit
 - Manometer combination
 - Monitored parking position for loading arm and gas arm
 - Controlled product valves DN80 product
 - Controlled gas valves and detonation safety barrier DN50
- Folding stairs 4-steps with monitored parking position
 - horizontal movable for a safe RTC-inspection
 - Pneumatic operation
 - Equipped with a protection cage
- Earthing test device for monitoring of the forced grounding of the railcars during loading.



Recommended optional equipment

- Light signaling and barrier systems,
- Wheel runners or wheel chocks with initiators for detecting the parking position of the road vehicles ,
- Rail hook for floor valve opening and safety shutdown when the railcars are rolling away,
- Fire detection system with fire detectors installed in exposed positions,
- Gas warning system with open-path gas warning devices and point detectors installed at exposed positions,
- Sprinkling system for reducing LPG gas concentrations caused by leaks,
- Fire-extinguishing monitors for the protection of persons or objects or hydro-shields to shield against flames, smoke and to vaporize vapors,
- Video surveillance system with swivel EX cameras installed at exposed positions,
- Railcar or tank truck number detection system, detection of danger number (formerly Kemler number) and UN number (substance number) on danger signs, double-sided video recording of the railcar compound for detection / documentation of damages, levers, freight paper.



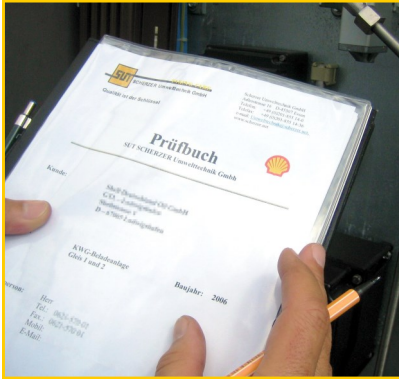

Training

Supervision

Commissioning

Training, supervision and commissioning is performed by highly qualified specialists of Dipl.-Ing. SCHERZER GmbH.

In-house training is generally combined with the function – test of the facility. Therefore it is secured that training activities are performed directly at control systems of the facility. During training, substantial functions are explained as well as the complete engineering system such as tag number system, circuit diagram etc.

Our specialists of supervision are sub – classified regarding Mechanic, earth work and foundations, electric and MSR. Further a Chief supervisor for coordination and as the contact person for the customer is foreseen. Detailed schedules and organization sheets and plans for supervision and commissioning are worked out.

After Sales Service

Our After Sales Service are performed by the specialists of our subsidiary company SCHERZER Umwelttechnik GmbH.

Maintenance contracts can be settled directly and will be split between mechanical section and EMSR.

Spare parts provision and optimization of the plants are, among other things, our core task and complete our service offer. Short term fault analyses are carried out by a remote diagnosis with VPN or modem connection for a quick solution of problems.



Our clients:

INEOS Manufacturing Deutschland GmbH, Lurgi Life Science, Minol AG, OAO Novatek, OOO RN-Komsomolskij, PKN ORLEN, ROSNEFT / RN Tuapsinskij NPZ, Ruhr Oel GmbH / BP Gelsenkirchen GmbH, TNK - BP / OAO Orenburgneft, Total Deutschland GmbH, VEBA OEL AG, SHELL Deutschland Oil GmbH, OMV, Vynova, u.a.

Various references:

Ruhr Oel GmbH / BP Gelsenkirchen GmbH (Gelsenkirchen / Germany)

2017: Detailengineering for modernisation / New construction of a LPG railcar unloading facility for C3 and C4 liquid gas

2016: Planning and delivery of components for modernisation of a railcar loading facility for LPG

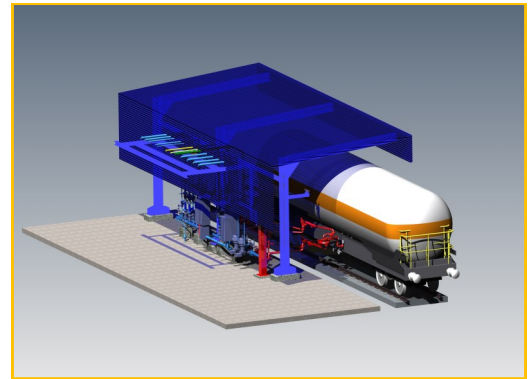

SHELL (Cologne / Germany) 2015:

Turnkey construction of a tank truck - loading - facility with 2 lanes for different LPG products (DME and Propan) for a major german mineral oil company.

Construction planning for civil, pipe construction, steel construction, EMSR * Automation systems and process visualization for loading in automated operation with high-availability and fail-safe PLC control * Complete integration into the customer-side TMS system * LPG loading arms for liquid and gas phases including safety separating clutch, expansion and nitrogen connection * loading skid incl. Mass metering system, control valves, shut-off valves, pressure measurement, a.o. * Weather protection cell as a local operator station * tank truck parking place and side plates as VAWS space * Fire water retention system including retention basin and drainage pumps * sprinkler system and fire fighting monitors incl. pressure boosting station for extinguishing water with redundant pumps * additional equipment such as gas warning system, BMZ, intercom system, access barriers, camera system, telephone.

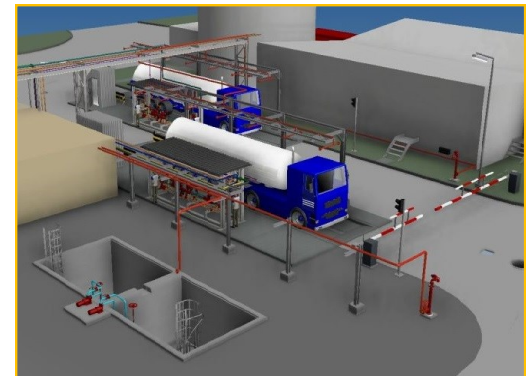

INEOS Manufacturing Deutschland GmbH (Cologne / Germany) 2015:

Planning of a new construction of a railcar unloading station with 3 unloading points for C4 - Butan.

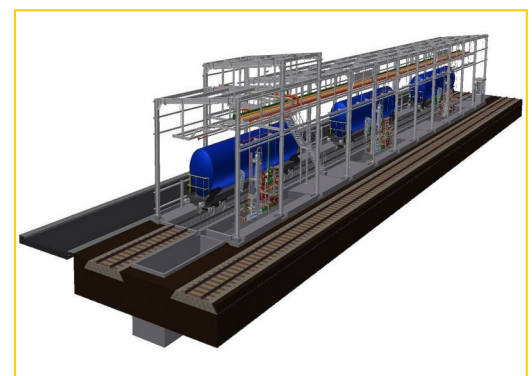

OAO Novatek (Westsibiria / Russia) 2014:

Reconstruction of a two track serial railcar loading facility for loading of railcars with LPG in automatic mode.
(2 x 10 RTC)



TNK - BP / OAO Orenburgneft (Zaikinski / Russia) 2012:

Tank truck unloading facility for liquid gas (LPG) with 4 lanes

2 LPG bottom unloading arms made of stainless steel (for product and gas) swivel mounted. * Complete SKID mounted at factory side in Essen-Germany (pre-piped, pre-cabled and pre-tested) * Complete control – and visualisation system (Simatic S7 , WIN CC and loading computer) * Pumps, valves and product system * Cables and terminal boxes * On-side control stations, traffic lights a.o. * Data logging with mass meter * Barriers * Electric– and MSR container (overpressure vented, clima controlled and heated)

Design temperature: -43°C to +42°C.



TNK - BP / OAO Orenburgneft (Zaikinski / Russia) 2010:

- 1) Two track railcar LPG loading facility with:
30 filling points incl. SPS control cabinets, WIN CC and loading computer
- 2) One track railcar Gascondensate - loading facility with:
3 loading arms for Gascondensate incl. SPS control cabinets, WIN CC and loading computer
- 3) Railcar unloading facility for liquid gas and Gascondensate
- 4) Dynamic track scale for commercial data logging of RTC's
From the LPG - estacade and gas benzine - estacade



OAO Novatek (Westsibiria / Russia) 2003:

Liquid gas loading facility with 10 filling systems swivel mounted for 2 tracks including:

Complete control– and automation system * Valve– and product system * CO2 fire fighting unit * Redundant power supply * Complete power– and MSR control systems, delivered pre-mounted and pre-tested in containers * Heating-, venting– and clima control system

Design temperature -50° C





LOADING YOUR FUEL

Dipl.-Ing. SCHERZER GmbH

www.scherzer.net

Headquarters

Dipl.-Ing. SCHERZER GmbH

Adlerstr. 16a

D - 45307 Essen

Phone: +49 / 201 / 855 14 - 0

Fax: +49 / 201 / 55 14 04

E-Mail: info@scherzer.net

www.Scherzer.net

Other brochures of Dipl.-Ing. SCHERZER GmbH

- Company profile
- Railcar – Loading systems
- Railcar – Unloading systems
- Railcar – Filling tube and Hydraulic systems
- Options for SCHERZER filling tube systems
- Study to compare Rail Tank Car ON-SPOT loading systems with serial loading systems
- LPG Loading– and Unloading systems
- Tankcar - Loading– and Unloading systems
- Ship - Loading– and Unloading systems
- Tankfarms, including handling plants and Vapor recovery units (VRU)
- Reference lists

We are pleased to send you our brochures on request.